

Isotron[®] accelerometer

Model 45A

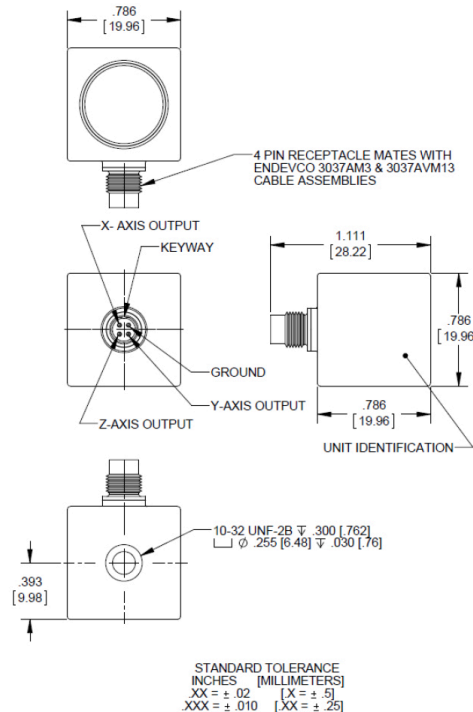

Key features

- General purpose triaxial Isotron[®] accelerometer
- Single, threaded 1/4-28 4 pin connector
- Wide frequency bandwidth
- High output available (500 mV/g and 1000 mV/g)
- IEEE P1451.4 TEDS capable

Model 45A is a cost effective general purpose triaxial Isotron accelerometer designed for use in a variety of applications. 45A is a 20 mm cube shaped Isotron accelerometer, featuring a single threaded 1/4-28 4 pin connector.

45A features an annular shear ceramic crystal which exhibits excellent output stability over time. The accelerometer incorporates an internal hybrid circuit with TEDS in a two-wire IEPE system which transmits its low impedance voltage output through the same cable that supplies the constant current power. Signal ground is connected to the outer case of the unit. Isolated mounting studs are available. Polarity inversion protection for the hybrid circuit is inherent in the circuit design.

45A is available in two sensitivities designated by a two digit suffix. The 45A18 has a sensitivity of 500 mV/g, while the 45A19 has a sensitivity of 1000 mV/g. The customer may select the mounting stud size included standard with the unit. The available stud sizes are 10-32, 1/4-28, M5 and M6. The stud size is designated following a dash after the model number.

This product is fully compliant to the European Union's Low Voltage Directive, 2006/95/EC and EMC Directive 2004/108/EC and is eligible to bear the CE Mark.

Our measurement product competencies:

Piezoelectric accelerometers | Piezoresistive accelerometers | [Isotron accelerometers](#) | Variable capacitance accelerometers | Pressure transducers | Acoustic sensors | Electronic instruments | Calibration systems | Shakers | Modal hammers | Cable assemblies

Isotron[®] accelerometer

Model 45A

Specifications

The following performance specifications conform to ISA-RP-37.2 and are typical values, referenced at +75°F (+24°C), 4 mA, and 100 Hz, unless otherwise noted. Calibration data, traceable to National Institute of Standards and Technology (NIST), is supplied.

Dynamic characteristics	Units	45A18	45A19
Range	g	±10	±5
Sensitivity	mV/g	500	1000
±10%			
Frequency response			
Resonance frequency			
Typical	kHz	28	
Minimum	kHz	21	
Amplitude response			
±5% y & z axis	Hz	0.5 to 6000	
±5% x axis	Hz	0.5 to 3000	
Phase response			
<5°	Hz	5 to 1500	
Sensitivity deviation over temperature			
-67°F to +257°F [-55°C to +125°C]	%	-5 to +15	
Transverse sensitivity			
Typical	%	≤5	
Maximum	%	7.5	
Amplitude linearity	%	<1	
Electrical characteristics			
Output polarity		Acceleration directed into base produces positive output	
DC output bias voltage			
Room temperature +75°F (+24°C)	Vdc	+11.4 to +13.0	
-67°F to +257°F [-55°C to +125°C]	Vdc	+8.0 to +15.5	
Output impedance	Ω	<100	
Noise floor			
Broadband			
1 Hz to 10 kHz	µg rms	50	40
Spectral			
1 Hz	µg/√Hz	15	11
10 Hz	µg/√Hz	4	3
100 Hz	µg/√Hz	1	1
1000 Hz	µg/√Hz	0.5	0.4
Grounding method		Signal ground connected to case	
Power requirements			
Supply voltage [1]	Vdc	+24 to +30	
Supply current	mA	+2 to +20	
Warm-up time [2]	s	3	
Digital communication (TEDS) device		DS2431X+U	
Environmental characteristics			
Temperature range, operating [3]		-67°F to +257°F [-55°C to +125°C]	
Humidity		Hermetically sealed	
Vibration limit [sinusoidal motion] [4]	g	500	
Shock limit [5]	g pk	5000	
Base strain sensitivity at 250 µstrain	g/µstrain	0.001	
Electromagnetic	equiv g/100 gauss	0.005	
Physical characteristics			
Dimensions		See outline drawing	
Weight	gram (oz)	40 (1.41)	
Case material		Titanium	
Connector		1/4-28 4 pin	
Mounting method		Threaded stud	
Mounting stud torque, recommended			
10-32 and M6 studs	lbf-in (Nm)	18 (2)	
M5 stud	lbf-in (Nm)	13 (1.5)	
1/4-28 stud	lbf-in (Nm)	30 (3.5)	
Calibration data supplied			
Sensitivity	mV/g		
Frequency response			
Amplitude response	%	20 Hz to 6 kHz, Y and Z axis	
	%	20 Hz to 3 kHz, X axis	
DC output bias voltage	Vdc		

Isotron[®] accelerometer

Model 45A

Model number definition

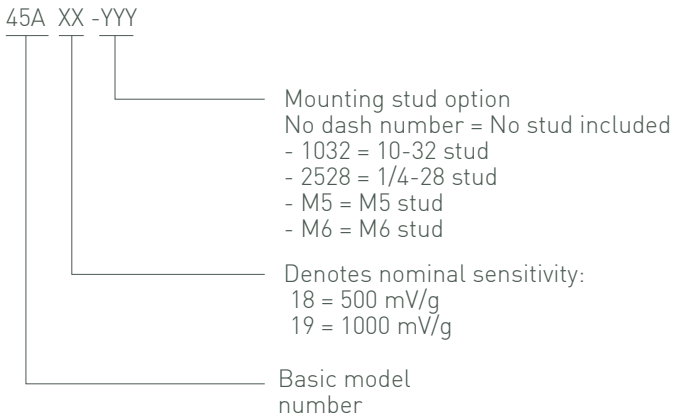

Contact

Endevco
Tel: +1 (866) 363-3826
www.endevco.com

Accessories

Product	Description	45AXX	45AXX-1032	45AXX-2528	45AXX-M5	45AXX-M6
C-003-CA-005-ZZZZ [6]	Cable assembly 4 pin to 3 BNC	Optional	Optional	Optional	Optional	Optional
3027AM3-ZZZ [6]	Cable assembly 4 pin to 3 BNC	Optional	Optional	Optional	Optional	Optional
3027AVM13-ZZZ	Cable assembly 4 pin to 4 pin	Optional	Optional	Optional	Optional	Optional
42676-1	Mounting stud 10-32 to 10-32	Optional	Included	Optional	Optional	Optional
42676-2	Mounting stud 10-32 to 1/4-28	Optional	Optional	Included	Optional	Optional
42676-4	Mounting stud 10-32 to M5	Optional	Optional	Optional	Included	Optional
42676-3	Mounting stud 10-32 to M6	Optional	Optional	Optional	Optional	Included
42673-1	Isolated mounting stud 10-32 to 10-32	Optional	Optional	Optional	Optional	Optional
42673-2	Isolated mounting stud 10-32 to 1/4-28	Optional	Optional	Optional	Optional	Optional
42673-3	Isolated mounting stud 10-32 to M6	Optional	Optional	Optional	Optional	Optional
42673-4	Isolated mounting stud 10-32 to M5	Optional	Optional	Optional	Optional	Optional
42675-1	Isolated adhesive mounting adapter	Optional	Optional	Optional	Optional	Optional

Notes

- Applications requiring a supply voltage of 20V, the full scale output voltage will be $\pm 5V$ [at room temperature]. Applications requiring a supply voltage of 18V, the full scale output voltage will be $\pm 3V$ [at room temperature].
- DC bias within 10% of final value.
- TEDS device operational temperature range is $-40^{\circ}F$ to $+185^{\circ}F$ [$-40^{\circ}C$ to $+85^{\circ}C$]. TEDS device will survive full operational range of accelerometer.
- Destructive limit.
- Destructive limit. Shock is a one-time event. Shock pulses of short duration may excite transducer resonance. Shock level above the sinusoidal vibration limit may produce temporary zero shift that will result in erroneous velocity or displacement data after integration.
- ZZZ or ZZZZ designates cable assembly length in inches.
- Maintain high levels of precision and accuracy using Endevco's factory calibration services. Call Endevco's inside sales force at +1 (866) 363-3826 for recommended intervals, pricing and turn-around time for these service as well as quotations for other products.



Continued product improvement necessitates that Endevco reserve the right to modify these specifications without notice. Endevco maintains a program of constant surveillance over all products to ensure a high level of reliability. This program includes attention to reliability factors during product design, the support of stringent Quality Control requirements, and compulsory corrective action procedures. These measures, together with conservative specifications have made the name Endevco synonymous with reliability.

ENDEVCO www.endevco.com Tel: +1 (866) 363-3826